

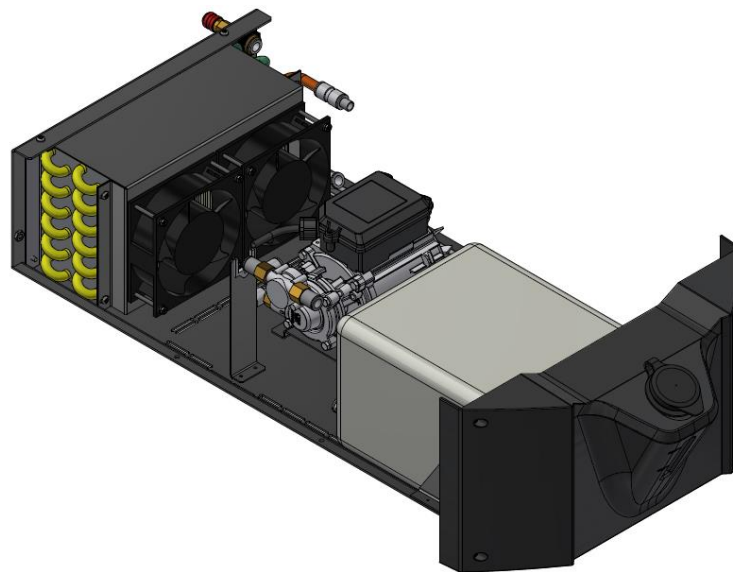

OWNER'S MANUAL

COOLING UNIT

MODEL: 6H/IF



Ensure to read this instruction manual thoroughly for safe and proper use of the product.



TABLE OF CONTESNTS

| | |
|--|----|
| 1. SAFETY INFORMATION | 3 |
| 1.1 OPERATING PRECAUTIONS | 3 |
| 1.2 PRECAUTIONS FOR POWER SUPPLY AND ELECTRIC SHOCK | 4 |
| 1.3 PRECAUTIONS FOR ROTATING PARTS..... | 4 |
| 1.4 PRECAUTIONS FOR DISASSEMBLING AND MODIFYING..... | 4 |
| 1.5 PRECAUTIONS FOR HANDLING OF PLASTIC PARTS | 5 |
| 1.6 PRECAUTION FOR COOLANTS..... | 5 |
| 2 PRODUCT SPECIFICATION | 6 |
| 2.1 TECHNICAL SPECIFICATIONS | 6 |
| 2.2 EXTERNAL DIMENSIONS..... | 6 |
| 2.3 RATED DUTY CYCLE | 7 |
| 3 INSTALLATION | 7 |
| 3.1 PRECAUTIONS BEFORE AND THE ENVIRONMENT OF THE INSTALLATION | 7 |
| 3.2 INSTALTION AND CONNECTION..... | 8 |
| 4 REMOVING THE COOLING UNIT..... | 9 |
| 5 START-UP / DRAINAGE | 9 |
| 6 MAINTENANCE..... | 10 |
| 7 MEANING OF GRAPHIC SYMBOLS | 11 |
| 7.1 COMPONENTS | 11 |
| 8 WIRING DIAGRAM..... | 13 |
| 9 COOLANT CIRCUIT DIAGRAM..... | 13 |

1. SAFETY INFORMATION

This section explains the safety precautions regarding operation of the Cooling unit 6H/IF.

The following safety alert symbols and signal words are used throughout the manual to ensure proper operation of the equipment and to prevent from various hazards that cause serious injury and damages. Indication and explanation for the symbols are as follows:

| <i>Symbols</i> | <i>Explanation</i> |
|---|---|
|  WARNING | WARNING gives information regarding possible personal injury or loss of life. |
|  CAUTION | CAUTION refers to minor personal injury or possible equipment damage. |

1.1 OPERATING PRECAUTIONS



To prevent serious injury or accidents, ensure to follow the instructions below:

|  WARNING |
|---|
| <ul style="list-style-type: none">• Be sure to read and understand the information in the manual before operating the equipment.• Safety and warning labels on the equipment indicate any possible risks. Keep these labels clean and legible at all times.• Observe the accident prevention regulations and any regional regulations.• Only authorized personnel or person with full understanding and experience of the equipment must perform installation, maintenance and repair of the equipment.• Use only well-maintained equipment. Repair or replace damaged parts at once.• Original spare parts have been specially designed for our equipment. The use of non-original spare parts may cause variations in performance or reduce the foreseen level of safety. We decline all responsibility for the use of non-original spare parts. |

|  CAUTION |
|---|
| <ul style="list-style-type: none">• The owner's manual must be kept at the location where the equipment is operated.• The equipment is designed for IP 23S degree of protection, which is intended indoor use.• If air-cooled welding torches are used, the cooling units needs to be turned off.• Do not use the cooling unit for purpose other than cooling welding torches.• This system is cooled by means of the forced circulation of air, and must therefore be placed in such a way that the air may be easily sucked in and expelled through the apertures made in the frame.• Do not use the cooling unit when the case and the cover are removed. |



1.2 PRECAUTIONS FOR POWER SUPPLY AND ELECTRIC SHOCK

To prevent from electric shock or burn injury, ensure to follow the instructions below:

| | |
|--|--------------------------|
|  WARNING | |
|  | ELECTRIC SHOCK can kill. |
| <p>Touching live electrical parts can cause fatal shocks or severe burns. The work circuits are electrically live whenever the output is on. The power line and internal circuits of this equipment are also live when the line disconnect switch on the connected welding power source is on.</p> <p>Leaving piled-up dust in the equipment may cause insulation deterioration and result in electrical shock and fire.</p> <ul style="list-style-type: none">• Do not touch live electrical parts.• Wear dry insulating gloves and other body protection that are free of holes.• Insulate yourself from work and ground using dry insulating mats or covers.• Be sure to disconnect the line disconnect switch on the connected welding power source before installing, maintaining or repairing this equipment. Make sure that there is no charged voltage before starting the work.• Properly install this equipment according to its Owner's Manual and national, state, and local codes.• Keep all panels and covers of this equipment securely in place.• Do not use worn, damaged, undersized, or poorly spliced cables.• Do not wrap cables around your body.• Remove dust by blowing moisture-free compressed air on each part periodically. | |

1.3 PRECAUTIONS FOR ROTATING PARTS

To prevent being caught/pinched by the rotating parts, ensure to follow the instructions below:

| | |
|--|------------------------------------|
|  CAUTION | |
|  | ROTATING PARTS may cause injuries. |
| <ul style="list-style-type: none">• Keep your hands, fingers, hairs and clothes away from the rotating cooling fan. | |

1.4 PRECAUTIONS FOR DISASSEMBLING AND MODIFYING

To prevent electrical shock, fire, injury from malfunction or error in the equipment, ensure to follow the instructions below:

| | |
|---|--|
|  CAUTION | |
| <ul style="list-style-type: none">• Do not disassemble/modify the equipment. Disassembling/modifying by customer is out of the warranty scope. | |

1.5 PRECAUTIONS FOR HANDLING OF PLASTIC PARTS

To prevent from electric shock or fire caused by the damage on plastic parts, ensure to follow the instructions below:

CAUTION

- **Do not apply external force or shock to the front panel, tank and catch tank. Otherwise, damage and malfunction may occur.**
- **If there is any abnormality in the plastic parts such as front panel, tank and catch tank, immediately stop the use and contact your dealer.**
- **If there is dirt on plastic parts, soak a soft cloth in water, alcohol or neutral detergent, wring it well and wipe off the dirt. Do not use organic detergent or chemical agent. Doing so may cause crack (breaking) and degrade the strength.**
- **Do not use the equipment source at location in which organic solvent, chemicals, cutting oil and composition oil adhere or atmosphere containing the above. Doing so may cause crack (breaking) and deterioration in the plastic part.**

1.6 PRECAUTION FOR COOLANTS

To prevent malfunction or error of the equipment and injury or accidents caused by the coolant, ensure to follow the instructions below:

CAUTION

- **Use only coolants approved by the equipment manufacturer. Using unapproved coolants can cause malfunction and error of the equipment and void the warranty.**
- **Read and follow the coolant manufacturer's instructions for safe handling of the coolant.**
- **Use protective equipment, such as safety goggles and gloves, when handling with the coolant.**

WARNING

- **In the event of undesirable contact with the coolant, follow the first aid measures given by the coolant manufacturer. If condition isn't restored, take a medical advice.**
- **In the event that the coolant ignites, follow the fire-fighting measures given by the coolant manufacturer.**

2 PRODUCT SPECIFICATION

This section explains the technical specifications, external dimensions and components of the Cooling unit 6H/IF.

2.1 TECHNICAL SPECIFICATIONS

| Model | 6H/IF |
|------------------------------|------------------------------------|
| Compatibility | Welbee Arxis series |
| Pump type: | Regenerative turbine electric pump |
| Supply voltage: | 400V 50/60Hz |
| Supply current: | Max. 0,95A /50Hz ; 1,1A /60Hz |
| Cooling power @ 1l/min: | 1,2 kW |
| P(MAX): | 0,45 Mpa (50Hz) / 0,55 Mpa (60Hz) |
| Type of connection(water): | Quick connectors NW5 |
| Number of connections(water) | 1 pair (rear) |
| Tank volume / Required fill: | 5,5l / 4l |
| Protection: | Flow meter |
| Conformity standard | IEC 60974-2 |
| Temperature range | 10 ~ 40 °C |
| Moisture range | 20 ~ 80% (no condensation) |
| Storage temperature range | -10 ~ 60 °C |
| Storage moisture range | 20 ~ 80% (no condensation) |
| External dimensions (WxDxH) | 391mm x 197mm x 826mm |
| Mass | 14kg |

2.2 EXTERNAL DIMENSIONS

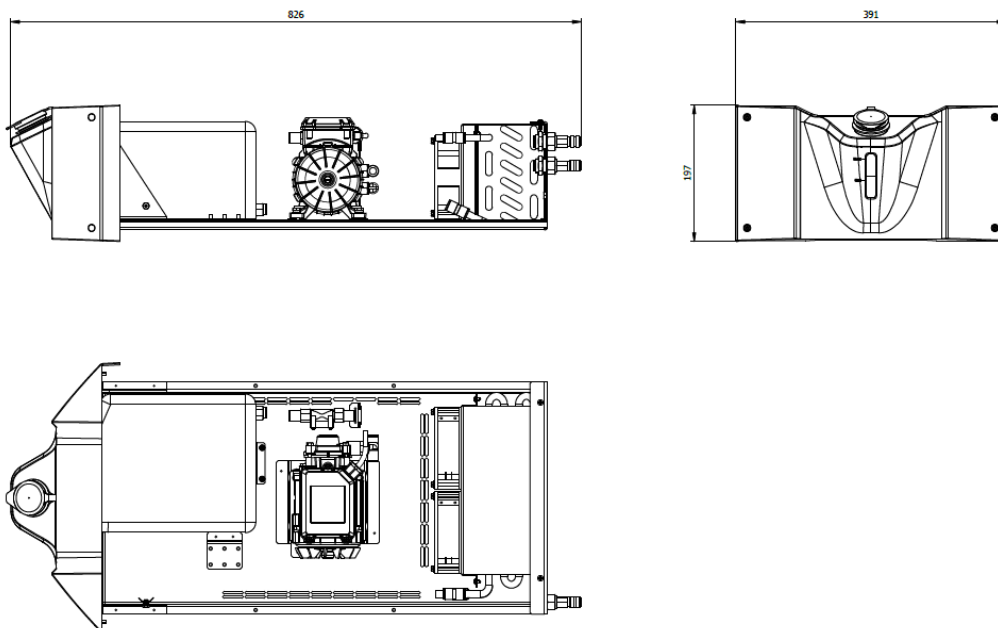



2.3 RATED DUTY CYCLE

The Cooling Unit is sized for cooling by means of coolant circulation in a continuous manner. As a work cycle, it is considered at 100%.

3 INSTALLATION

This section explains the precautions before and the environment of the installation, the electrical wiring and the mounting of the Cooling unit.

3.1 PRECAUTIONS BEFORE AND THE ENVIRONMENT OF THE INSTALLATION

| | |
|--|--------------------------|
|  WARNING | |
|  | ELECTRIC SHOCK can kill. |
| <ul style="list-style-type: none">• Be sure to disconnect the line disconnect switch on the welding power source before installing this equipment on it. Make sure that there is no charged voltage before starting the work.• Read the precautions for power supply and electric shock and follow them during the whole process of installation. | |

3.2 INSTALTION AND CONNECTION

1) Push the cooler inside the welding source along the rails.

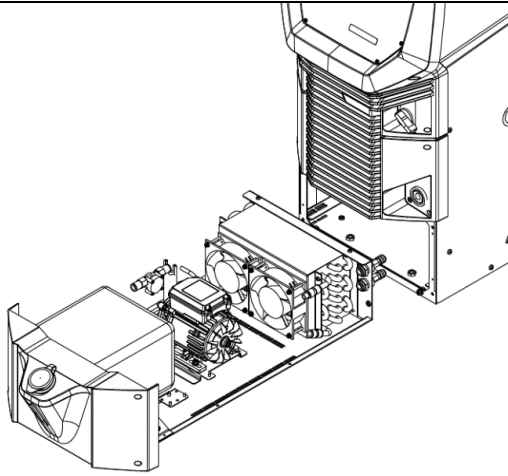

2) Leave gap between 20-25 cm.

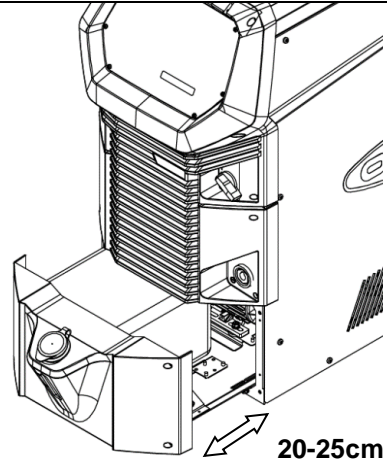

3) Connect the flow sensor connector (6-pole) to the right connector in the welding source.

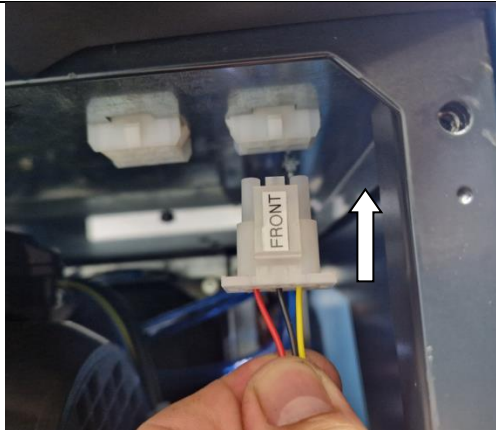

4) Connect the power connector (9-pole) to the left connector in the welding source.

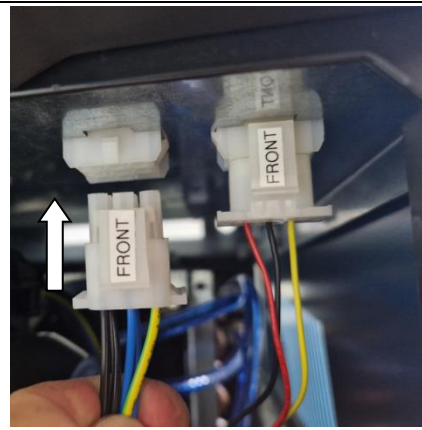

5) Push the cooler all the way into the welding source. Screws: M4x12 (T20) – 4 pcs (code: 632079)

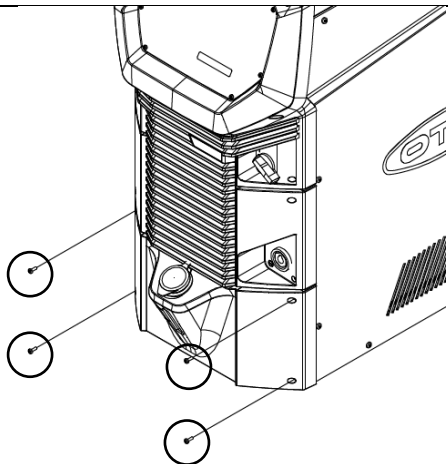

6) Screws on the back side M5x12 – 2 pcs (code: 630100).

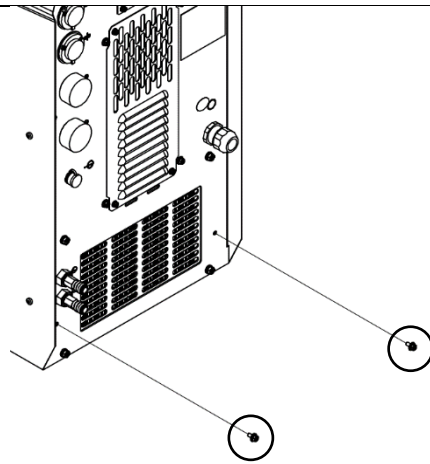

4 REMOVING THE COOLING UNIT

Removal of the cooling unit is carried out in the same way as described in chapter 3. INSTALLATION, except that it's carried out in the reverse order.

5 START-UP / DRAINAGE

This section explains the process which needs to be made before first usage or a longer period of inactivity of the Cooling unit , also in the case in which the electro pump does not go under pressure. This process called drainage is necessary to undertake in order to eliminate all the air bubbles present within the hydraulic circuit.

 **WARNING**

- Read the precautions for coolants and follow them during the whole process of start-up.

Drainage:

1. Pour the coolant into the tank so that the level of the coolant is between the MIN and MAX mark. As coolant, mixtures shown below can be used.



| <i>Descriptions</i> | <i>Part No.</i> | <i>Using temperature</i> | |
|----------------------|-----------------|--------------------------|-------------------|
| BINZEL BTC-20 NF | 606649 | from -15°C to 90°C | For general use |
| DAIHEN SUPER COOLANT | 2670-033 | from -15°C to 90°C | For general use |
| | 2670-034 | from -30°C to 90°C | For cold district |



2. Using the Pipetting Bulb (606499), squeeze the bulb fully and hold in this condition.
3. While the pipette bulb is squeezed, connect the connector on the end of the hose with the blue connector on the front of the cooling unit.
4. Release the pipette bulb and wait until the coolant (and maybe air bubbles) fully fill the bulb as well as the hose.
5. Disconnect the pipette bulb and the hose from the Cooling Unit and empty the coolant into the tank.
6. Repeat the process from point 2 to 5 until the air bubbles at point 4 no longer appear. Usually two to three repetitions are required.
7. Adequately (by color) connect the cooling unit to the wire feeder with water hose.
8. Turn on the welding power source and press the Water / TORCH button on the operational panel (see welding power source owner's manual), to engage the cooling unit.
9. After a minute re-check the coolant level, and add additional coolant if necessary.

Note: On long torches, such as a water-cooled push-pull torch, it may be necessary to restart the power source multiple times to clear the E-501 error and allow the coolant to flow back to the cooler and engage the flow switch.
10. The Cooling Unit is ready to use.

6 MAINTENANCE

This section explains the necessary maintenance work to ensure the proper functioning of the Cooling unit.





| | |
|---|--------------------------|
|  WARNING | |
|  | ELECTRIC SHOCK can kill. |
| <ul style="list-style-type: none">• Be sure to disconnect the line disconnect switch on the connected welding power source before maintaining this equipment. Make sure that there is no charged voltage before starting the work.• Read the precautions for power supply and electric shock and follow them during the whole process of installation. | |

| | |
|---|----------------------------|
|  CAUTION | |
|  | HOT PARTS may cause burns. |
| <ul style="list-style-type: none">• Some components can be extremely hot immediately after welding is performed. Wait until the parts cool down, when touching. Failure to observe the demand may result in burn. | |

To maintain the proper functioning of the equipment, ensure to follow the instructions below:

- Make sure no strange vibration, buzzing noise, and burning smell are generated from the cooling unit.
- No excessive heat is generated from the cable connections.
- Make sure all joints are tight and that there are no leaks.
- The cooling fan is running normally.
- Periodically check the level of the coolant.
- Add coolant whenever it drops below the MIN mark.
- Periodically clean the fans, heat exchanger and the inside with compressed air to eliminate the dust that reduces the cooling capacity.

7 MEANING OF GRAPHIC SYMBOLS

| | | | | |
|---|---|---|--|---|
| 1 | 2 | 3 | 4 | 5 |
|  |  |  |  |  |

●1 Coolant inlet and outlet ●2 Warning! ●3 Before using the equipment you should carefully read the instructions included in this manual ●4 Product suitable for free circulation in the European Community ●5 Do not throw away with household waste; observe the local regulations regarding disposal

7.1 COMPONENTS

| No. | Order code | Description | Spec. | Q'ty | Remarks |
|-----|------------|-----------------------------|-------------|-------|---------------|
| 1 | 632209 | PUMP | | 1 | with fittings |
| 2 | 631672 | HEAT EXCHANGER | 258477 | 1 | |
| 3 | 631756 | CONNECTOR RED NW 5 - G 1/4 | 003204/R | 1 | |
| 4 | 631757 | CONNECTOR BLUE NW 5 - G 1/4 | 003204/B | 1 | |
| 5 | 631758 | FITTING KQ2E10-G02A | KQ2E10-G02A | 2 | |
| 6 | 631760 | FITTING KQ2H10-00A | KQ2H10-00A | 2 | |
| 7 | 631885 | SEAL 13.0 X 18.0 X 1.5 CU | | 2 | |
| 8 | 632210 | TANK | V2004D00 | 1 | with fittings |
| 9 | 631974 | TANK CAP | V2004D02 | 1 | |
| 10 | 631775 | LOWER COVER | V1011G03 | 1 | |
| 11 | 632211 | FLOW SENSOR | V2004F00 | 1 | with fittings |
| 12 | 689241E1 | FAN TP2123XST | TP2123XST | 2 | |
| 13 | 631832 | HOSE 10/6.5 BLUE | TU1065BU | 1,5 m | |
| 14 | 631751 | WIRING | | 1 | |
| 15 | 631866 | METAL BASE FRAME | V2004B01 | 1 | |
| 16 | 631658 | METAL FAN HOLDER | V2004B02 | 1 | |
| 17 | 631864 | TANK HOLDER | V2004B03 | 1 | |
| 1A | 606334 | MECHANICAL SEAL (SET) | | 1 | for pump No.1 |

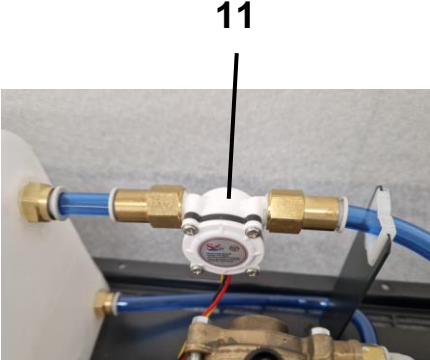
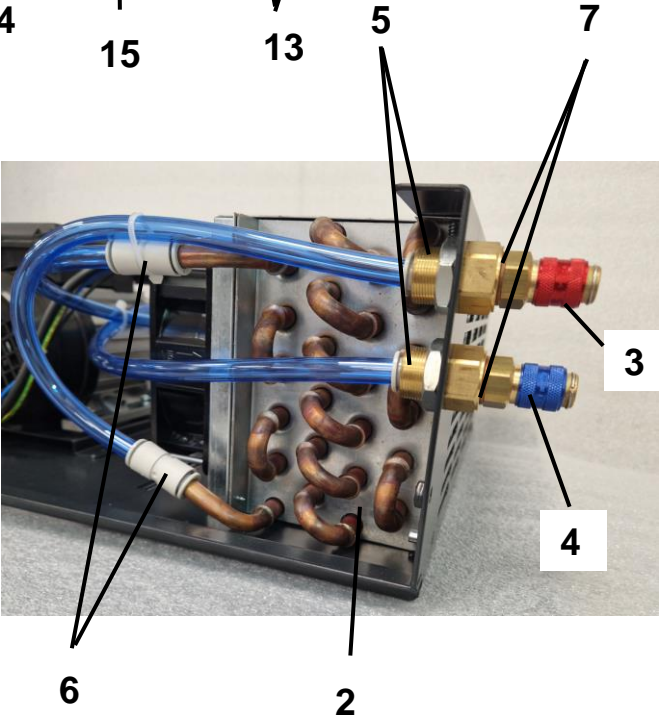
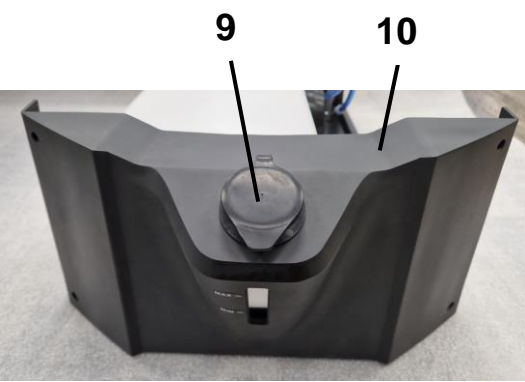
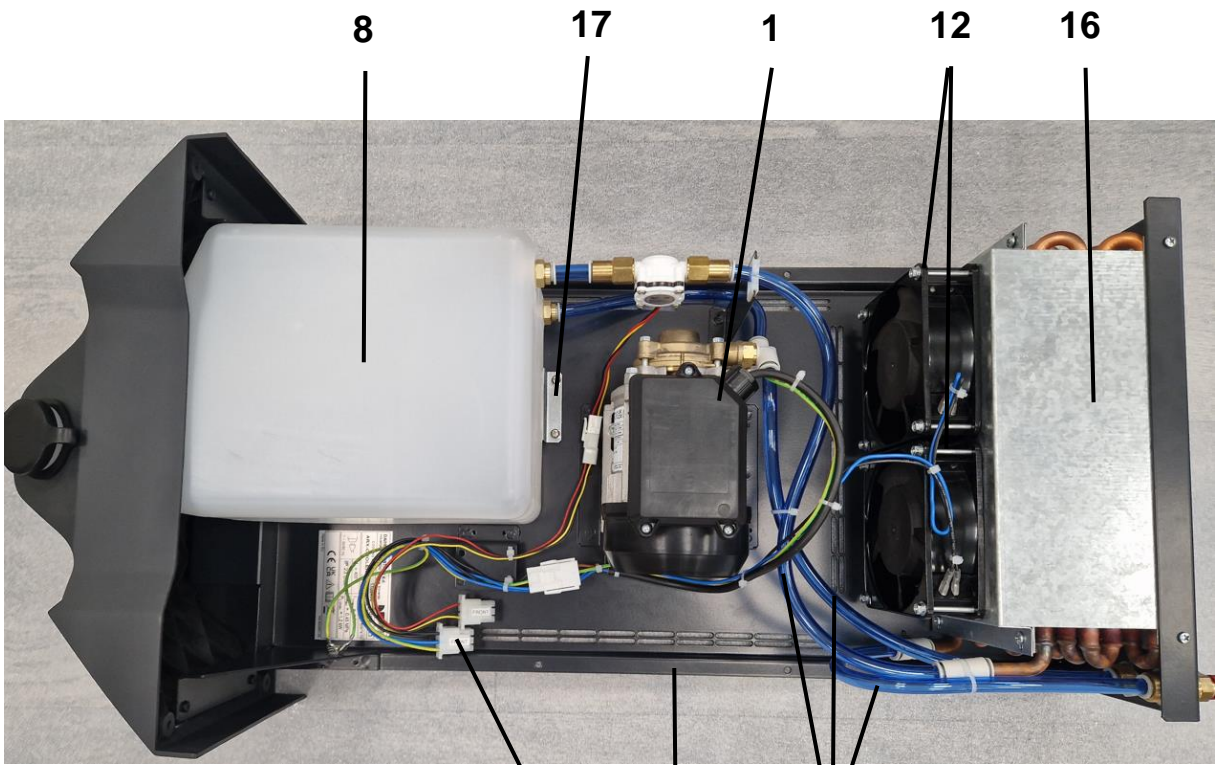

8 WIRING DIAGRAM

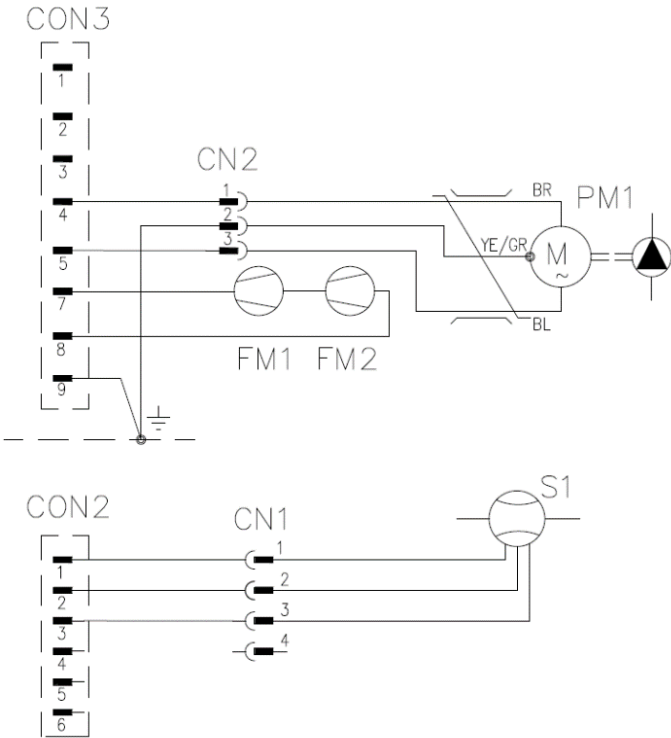

- PM1 - Pump motor
- FM1-2 - Fan
- S1 - Flow sensor
- CN1-2 - Connector internal
- CON1-2 - Connector to power source

9 COOLANT CIRCUIT DIAGRAM

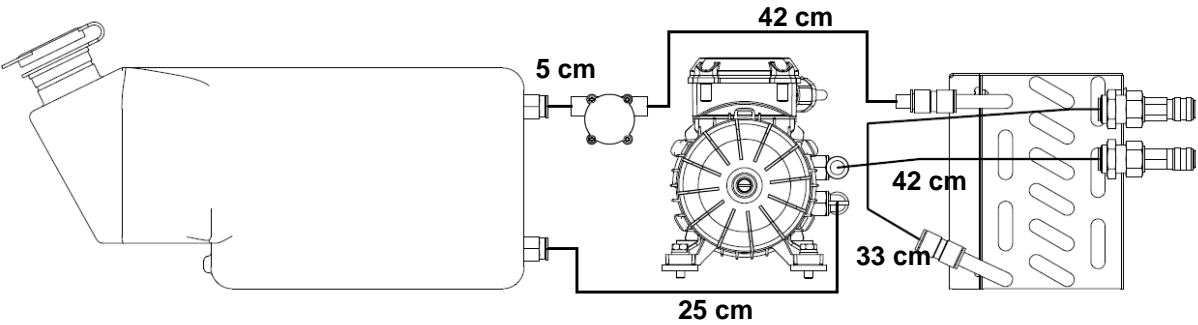



DAIHEN Corporation

4-1, Koyochonishi, Higashinada-ku, Kobe, Hyogo 658-0033, Japan
Phone: +81-78-275-2006, Fax: +81-78-845-8159

DAIHEN Inc.

1400 Blauser Drive Tipp City, Ohio 45371, USA
Phone: +1-937-667-0800, Fax: +1-937-667-0885

DAIHEN MEXICO S.A. de C.V.

Mineral de Valenciana 645, Edif. F3y4 Centro de Negocios Santa Fe
Puerto Interior Silao de la Victoria, Gto. CP 36275
Phone: +52-472-748-9435

OTC DAIHEN EUROPE GmbH

Krefelder Strasse 677, D-41066 Mönchengladbach, Germany
Phone: +49-2161-694970, Fax: +49-2161-6949761

DAIHEN VARSTROJ welding cutting and robotics d.d.

Industrijska ulica 4, 9220 Lendava - Lendva, Slovenija
Phone: +386-25-788-826, Fax: +386-25-751-277

OTC Industrial (Shanghai) Co., Ltd.

6F, Building B, ORIENTO Plaza, 388 North Fuquan Road,
Changning District, Shanghai, China 200335
Phone: +86-21-5882-8633, Fax: +86-21-5882-8846

OTC (Taiwan) Co., Ltd.

2F No.153, Huanbei Rd., Chung Li City, Taoyuan Hsien, Taiwan
Phone: +886-3-461-3962, Fax: +886-3-434-2394

OTC DAIHEN Asia Co., Ltd.

23/43, 16th F1.Sorachai Building, 23 Soi 63 Sukhumvit Road,
Klongtonnua, Wattana, Bangkok 10110, Thailand
Phone: +66-2-714-3201, Fax: +66-2-714-3204

OTC DAIHEN INDIA PVT.LTD.

V. M. TOWER, Plot No. 54A, Ground Floor Unit-1,
Sector-18, Gurugram-122015 Haryana, India
Phone:+91 124-4239368, +91 124-4239364

PT.OTC DAIHEN INDONESIA

Blok G1A-20, Jl. Kenari II, Delta Silicon V,
Lippo Cikarang Industrial Park, Bekasi 17550 Indonesia
Phone:+6221-2957-7566, Fax:+6221-2957-7567

DAIHEN Korea Co., Ltd.

85, Hyeongoksan-ro, Cheongbuk-myeon, Pyeongtaek-si, Gyeonggi-do, 451-831, Korea.
Phone: +82-31-686-7459, Fax: +82-31-686-7465

Upon contact, advise MODEL and MANUAL NO.

210901